

Worldwide Distributors

Baltic, Nordic

Von Gegerfelt Photonics
Tel.: +49-6251 860 99 20
Fax: +49-6251 860 99 17
dvg@vgphotonics.eu
www.vgphotonics.eu

Italy

LOT-Oriel Italia
Tel.: +39-02 26 82 21 04
Fax: +39-02 26 82 50 07
info@lot-oriel.it
www.lot-oriel.it

Singapore/Malaysia

PhotoniTech Pte Ltd
Tel.: +65-65 70 33 86
Fax: +65-62 33 91 71
csales@photonitech.com
www.photonitech.com

Benelux

Applied Laser Technology (ALT)
Tel.: +31-499 37 53 75
Fax: +31-499 37 53 73
info@alt.nl
www.alt.nl

Japan

Japan Laser Corp.
Tel.: +81-352 85 08 61
Fax: +81-352 85 08 60
lase@japanlaser.jp
www.japanlaser.jp

Taiwan

Tayhwa Technology Co. Ltd.
Tel.: +88-62 23 56 97 37
Fax: +88-62 23 56 96 59
tayhwa@tayhwa.com.tw
www.tayhwa.com.tw

China

Pinnacle Scientific Corporation
Tel.: +86-571 88 22 51 51
Fax: +86-571 88 22 52 52
sales@psci.cn
www.psci.cn

Korea

DongWoo Optron Co., Ltd.
Tel.: +82-317 65 03 00
Fax: +82-317 65 02 22
optron@optron.co.kr
www.optron.co.kr

Turkey

Mitra Anonim Sirketi
Tel.: +90-212 347 47 40
Fax: +90-212 347 47 45
info@mitralaser.com
www.mitralaser.com

France

Photon Lines
Tel.: +33-130 08 99 00
Fax: +33-130 08 99 09
info@photonlines.com
www.photonlines.fr

Poland

Amecam
Tel.: +48-22 207 22 78
Fax: +48-22 207 28 77
amecam@amecam.pl
www.amecam.pl

UK

Photon Lines Ltd.
Tel.: +44-12 95 72 42 25
Fax: +44-12 95 72 42 26
info-uk@photonlines.com
www.photonlines

Israel

Militram
Tel.: +97-299 58 18 60
Fax: +97-299 57 43 83
militram@militram.com
www.militram.com

Spain

LASER Technology S.L.
Tel.: +34-937 50 01 21
Fax: +34-937 50 03 23
josecochon@laser-technology.com
www.laser-technology.com

USA

Market Tech, Inc.
Tel.: +1-83 14 61 11 01
Fax: +1-83 14 61 11 36
info@markettechinc.net
www.markettechinc.net

For Life Science Applications

Germany, Austria, Switzerland, Scandinavia

Von Gegerfelt Photonics

Tel.: +49-6251 860 99 20
Fax: +49-6251 860 99 17
dvg@vgphotonics.eu
www.vgphotonics.eu



Omicron-Laserage Laserprodukte GmbH

Raiffeisenstrasse 5e

63110 Rodgau, Germany

Tel.: +49-61 06 82 24-0

Fax: +49-61 06 82 24-10

mail@omicron-laser.de

www.omicron-laser.de



ISO 9001:2008



LEDMOD series

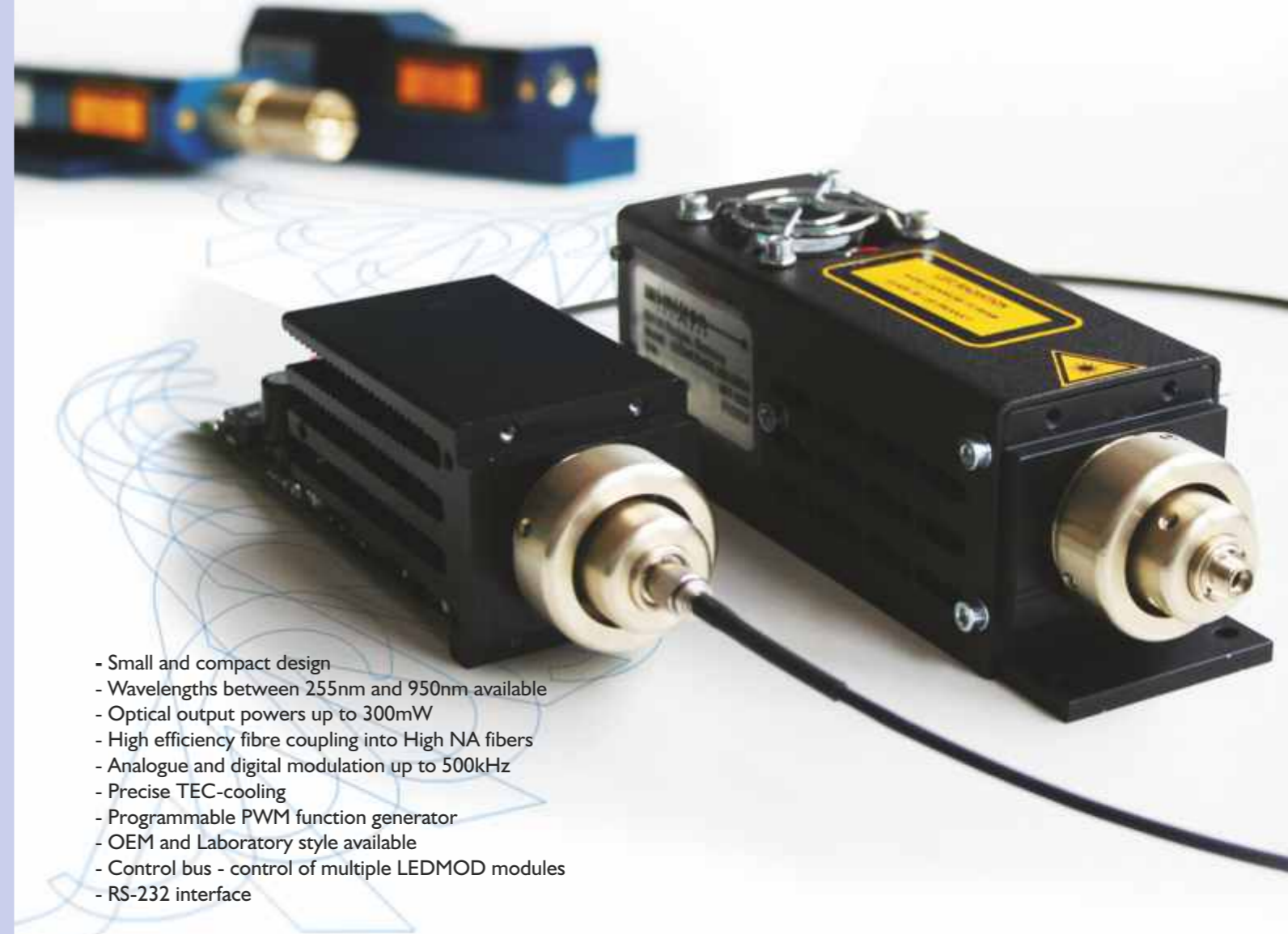

- Small and compact design
- Wavelengths between 255nm and 950nm available
- Optical output powers up to 300mW
- High efficiency fibre coupling into High NA fibers
- Analogue and digital modulation up to 500kHz
- Precise TEC-cooling
- Programmable PWM function generator
- OEM and Laboratory style available
- Control bus - control of multiple LEDMOD modules
- RS-232 interface

LEDMOD OEM Series / LEDMOD LAB Series - TEC-cooled high power LED modules from 255nm to 950nm with optional fibre-coupling for OEM or laboratory use.

The temperature-stabilized, high-power LED modules of the LEDMOD series are intended for users in the industry, research and science sector. Applications in biotech, medical technology, microscopy, photocatalysis and fluorescence excitation are only some of the applications in which these laboratory light sources are employed. The modules are available in many wavelengths, from deep UV (255 nm) to the infrared range (950nm). The optional, highly efficient fibre coupling, the integrated interface RS-232, the Windows™ compatible software for programming and control, and the diverse operating modes, make these modules flexible, compact and extremely long-lived sources of light, which up to now could not be realized with classical methods. The possibility of external analogue and digital modulation, the programmability of an internal frequency PWM with variable duty-cycle and the controllability over the serial interface, enable adaptation of the source of light to nearly every application. The high optical output powers (particularly in the UV range at 365nm, 385nm and 405nm) represent a long-lived alternative to UV discharge lamps. LEDMOD LED modules, with emission in the blue, green, yellow, red and infrared range, as well as a white light source, represent a genuine, wavelength-stable alternative source of light for halogen lamps. Reproducible results of measurement are thus guaranteed!

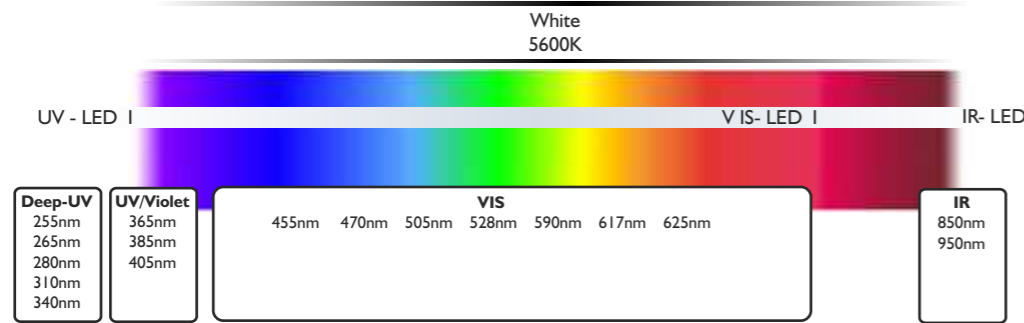

LEDMOD OEM

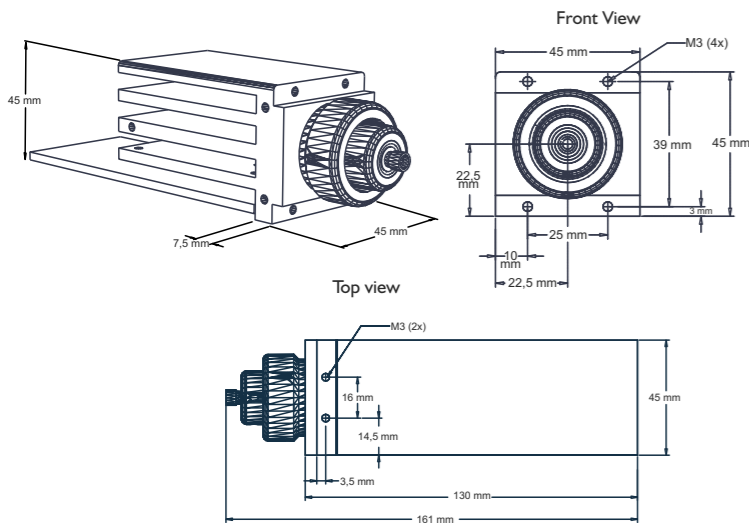

LEDMOD LAB

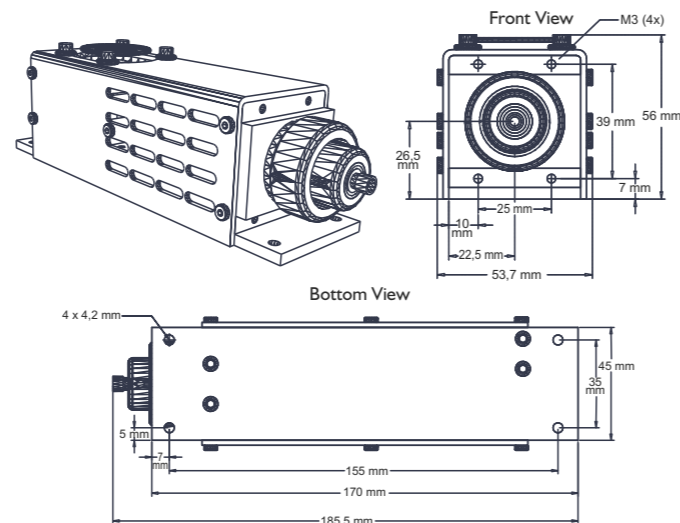

Wavelengths & Powers
(other wavelengths and powers on request)

LEDMOD OEM / LAB

Deep-UV*:

255nm / 150µW
265nm / 400µW
280nm / 600µW
310nm / 500µW
340nm / 350µW

UV / Violet:

365nm / 250mW
385nm / 300mW
405nm / 250mW

VIS:

455nm / 300mW
470nm / 300mW
505nm / 50mW
528nm / 100mW
590nm / 100mW
617nm / 300mW
625nm / 200mW

IR:

850nm / 170mW
950nm / 150mW

White:

5600K / 200mW

Free space emission angle	120 - 130° (Deep-UV 10°)
Temperature control	active peltier cooling (TEC)
External modulation capabilities	up to 500kHz by analogue 0...5V signal and / or digital by TTL signal
Internal modulation capabilities	Up to 200kHz with programmable frequency and duty cycle
Power setting resolution	internal: 12Bit external: analogue
Computer interface	RS-232 terminal communication, 57600 baud
Operation modes	1.) external analogue control (0...5V) for output power and additional external TTL signal for ON/OFF modulation 2.) internal power control with external TTL for ON/OFF modulation 3.) internal power control CW (continuous wave) operation (no external signals necessary) 4.) internal power control + programmable frequency and duty-cycle for ON/OFF modulation (no external signals necessary) 5.) external power control (0...5V) for output power + programmable frequency and duty cycle for ON/OFF modulation
Control interface	15-pin Sub-D connector
Dimensions (without fibre coupling unit)	51x49x150mm (HxBxL)
Weight	350g
Supply voltage	9VDC-15VDC
Power consumption	27W max. < 1W in standby
Environmental temperature	0°C-45°C
Certifications	CE, UL/CSA on request
Special features	* Modular mechanical and electronic principle * Control bus architecture for control of multiple LED units * Interlock function * Over-TEMP protection * Remote control
Options	* High-efficiency fibre coupling into high-NA POF and fused silica fibres (fibre coupling efficiency is depending on wavelength and fibre diameter)

* Deep UV 255-340 only available with free space emission

more information: www.omicron-laser.de